



North American Dispense Systems, Inc.



Nitrogen Regulator

PRESSURE REGULATOR with Integral Relief Valve

Designed to Serve the Beverage Industry

NADS SBN 2000 series Compressed Gas Regulator is recommended for use with beverage dispensing systems that require compressed gas at a variable flow and constant pressure. It is intended for use with cylinder gas applications, and is recommended for use with CO₂, air and nitrogen.

All regulators are equipped with integral relief valves and back flow check valves in the outlet fittings.



MODEL NUMBERS

GR2101

GR2102

DESCRIPTION

Body Only

Double Gauge with Shut Off

**North American
Dispense Systems, Inc.**



North American Dispense Systems, Inc.

Regulator Features

Integral Non-Adjustable Pressure Relief Device (see Illustration "A")

The NADS SBN 2000 series Regulator features an integral pressure relief device designed to protect product containers from potentially dangerous pressure build-up. The pressure relief capacity functions in accordance with industry guidelines for pressurized dispensing systems.

Seat Cartridge for Convenient Service and Replacement (see Illustration "B")

Equipped with a sintered filter element to prevent solid contaminants from entering the cartridge, the NADS SBN 2000 series Regulator provides ease of service repair and replacement. All repaired and replacement seat cartridges are factory tested and inspected before approved.

Outlet Check Valve Protects Reverse Flow of Liquid and Gas (see Illustration "C")

The outlet fitting of each NADS SBN 2000 series Regulator contains a check valve to protect the regulator from liquids and other contaminants.

Safety First

The NADS SBN 2000 series Regulator is equipped with an internal pressure-relief device built in as an integral part of the regulator body in system applications. The following procedures must be followed:

1. Always use pressure-relief devices of sufficient capacity in the secondary pressure lines. This downstream pressure relief device may be: an integral part of the secondary regulator; externally mounted; or in-line (providing no piece of equipment is between the pressure-relief device and the regulator.)
2. Do not attempt to remove, plug, block or interfere with the function of any pressure relief device.
3. A check valve must always be installed at each regulator or at each manifold outlet in liquid dispensing application to prevent reverse flow and possible introduction of liquids and other contaminants into the regulator.
4. The NADS SBN 2000 Regulator must not be used when temperature or pressure may exceed rated operating conditions.
5. NADS regulators are not intended for use in life support systems.

Spare Parts for Nitrogen Regulator

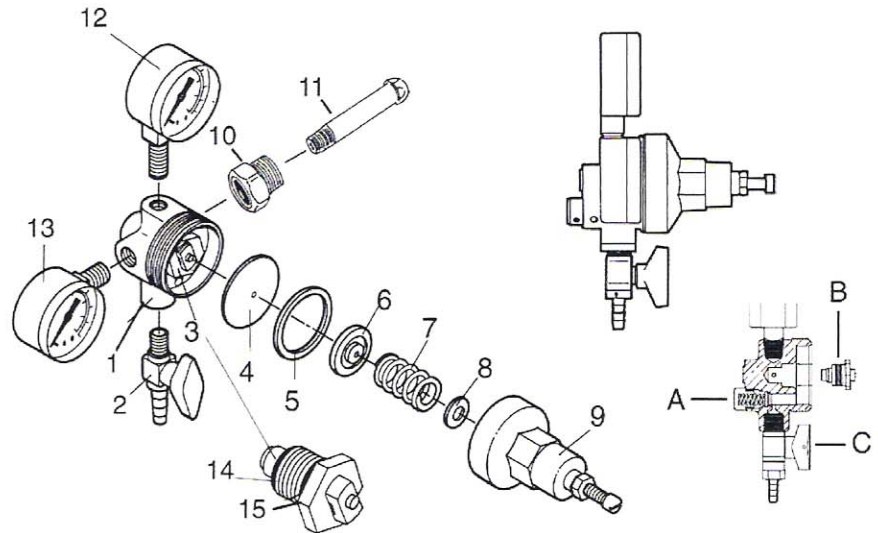

SPARE PARTS

MODEL NUMBER

1.	BODY	70012
2.	SHUT OFF VALVE (WITH BALL CHECK)	70030
3.	SEAT CARTRIDGE	70028
4.	DIAPHRAGM	70014
5.	BONNET GASKET	70022
6.	DIAPHRAGM SEAT	70015
7.	BONNET SPRING	70020
8.	ADJUSTING SCREW BUTTON	70021
9.	BONNET ASSEMBLY	70013
10.	TANK CONNECTOR NUT	70097
11.	TANK CONNECTOR	70098
12.	0-60 LB. GAUGE (R.H.T.)	70071
	0-100 LB. GAUGE (R.H.T.)	70129
	0-160 LB. GAUGE (R.H.T.)	70254
13.	0-3000 LB. GAUGE (L.H.T.)	70070
14.	SEAT CARTRIDGE O-RING, SMALL	70010
15.	SEAT CARTRIDGE O-RING, LARGE	70011
N/S	L.H.T. PLUG	70072
N/S	R.H.T. PLUG	70081
N/S	REPAIR KIT (SEAT CARTRIDGE & DIAPHRAGM)	70229